

ENERGIZER 364/363

SILVER OXIDE

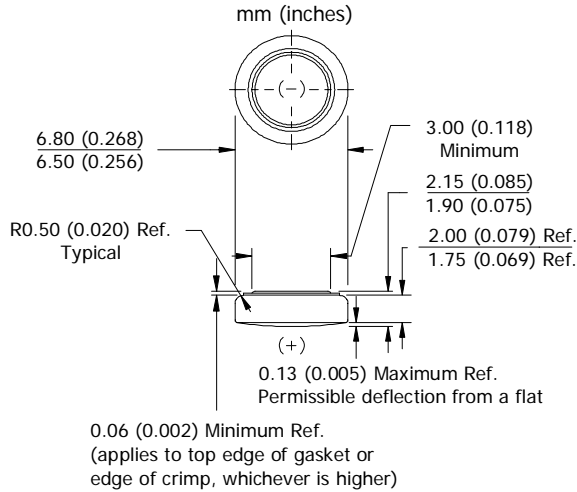

Industry Standard Dimensions



DESIGNED FOR USE ON CONTINUOUS LOW DRAIN  
HIGH PULSE ON DEMAND

Specifications

<b>Chemical System:</b>	Silver Oxide (Zn/Ag <sub>2</sub> O)
<b>Designation:</b>	ANSI-1175SO, IEC-SR60
<b>Nominal Voltage:</b>	1.55 Volts
<b>Typical Capacity:</b>	20 mAh* (to 1.3 volts)
<b>Capacity Test:</b>	68K ohm continuous drain at 21°C
<b>Typical Weight:</b>	0.37 grams (0.012 oz.)
<b>Typical Volume:</b>	0.08 cubic centimeters (0.005 cubic inch)
<b>Impedance (40 Hz):</b>	5 to 15 ohms

\* Varies according to the applied load, temperature, and cutoff voltage.

Cross Section

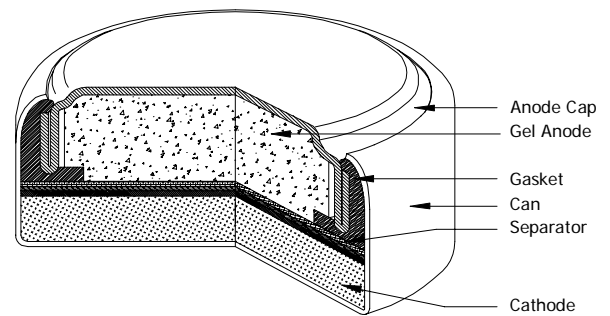

Typical Discharge Characteristics

Typical Performance at 21°C (70°F)

**Schedule:** Continuous  
**Typical Drain @1.55V:**  
0.023 milliamperes  
**Load:** 68K ohm

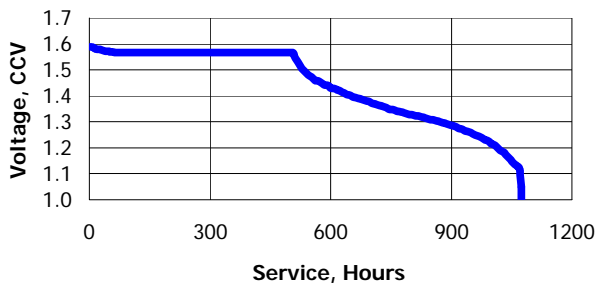

<u>Schedule</u>	<u>Typical Drains</u> at 1.55V (milliamperes)	<u>Load</u> (ohm)	<u>Cutoff</u> 1.3V (hours)
Continuous	0.023	68K	870

Temperature Characteristics

Typical Performance at Low Discharge Rates

Service Effects

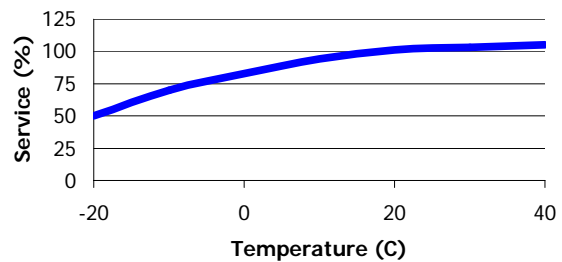

Storage Effects

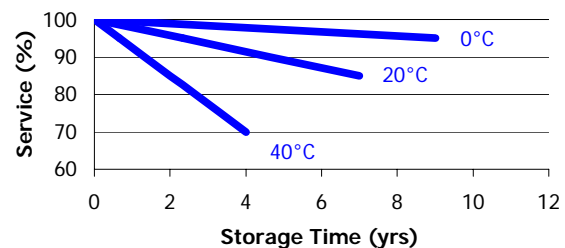

Important Notice

This datasheet contains typical information specific to products manufactured at the time of its publication.

©Energizer Holdings, Inc. - Contents herein do not constitute a warranty.